

### Background Information on Tankless Water Heaters in Space Heating Applications

In recent years the use of tankless water heaters in the United States has grown significantly in residential and commercial applications. As tankless water heaters gained acceptance in the water heating market, customers sought to use them in a wide variety of applications because of their reliability, efficiency, price, and features. The proliferation of tankless water heaters in space heating only (closed loop) applications began because the price of a tankless water heater was usually much less than the price of a boiler that was typically used in a space heating only application.

Tankless Water Heaters are typically certified to the American National Standard/CSA Standard for Gas Water Heaters ANSI Z21.10.3/CSA 4.3. The Scope of this standard includes water heaters for use with combination potable water/space heating applications. Boilers are typically certified to the American National Standard/CSA Standard for Gas-Fired Low Pressure Steam and Hot Water Boilers ANSI Z21.13/CSA 4.9.

People in the space heating industry soon began to question if tankless water heaters that were certified for potable water/space heating applications were also acceptable for space heating only applications. This led to instances of code officials, in some states, rejecting installations of tankless water heaters in space heating only applications.

In November 2006 a request was made to ANSI's Technical Advisory Group (TAG) to provide additional coverage in the form of definitions or Scope refinements to the standards to further identify boilers and water heaters. At this meeting it was determined that water heaters certified to the ANSI Z21.10.3 standard should only be used in potable water and combination potable water/space heating applications (open loop) as specified in the current Scope of the standard and that units certified under this Standard were not applicable for space heating only (closed loop) applications.

### Rinnai Tankless Water Heaters in Space Heating Applications

Rinnai Tankless Water Heaters are certified to the American National Standard/CSA Standard for Gas Water Heaters ANSI Z21.10.3/CSA 4.3. The Scope of this standard includes water heaters for use with combination potable water/space heating applications, commonly referred to as open loop systems. The Scope of this standard does not apply to products that will be used in space heating only applications, commonly referred to as closed loop systems. Products intended for use in closed loop systems are typically certified to the American National Standard/CSA Standard for Gas-Fired Low Pressure Steam and Hot Water Boilers ANSI Z21.13/CSA 4.9. The Scope of this standard applies to products that will be used in space heating only (closed loop) systems.

For this reason, Rinnai America Corporation does not recommend or promote the use of its Tankless Water Heaters in any space heating only (closed loop) applications (see Figure 1). Rinnai will not honor warranties for units installed after May 1, 2008 in closed loop applications. Rinnai Tankless Water Heaters may be used in combination potable water/space heating (open loop) applications (see Figure 2). Rinnai Tankless Water Heaters may also be used in combination potable water/space heating (open loop) applications where the space heating system is a closed heating circuit that is separated from the Rinnai heated potable water supply via a heat exchanger (see Figure 3).

**NOTE:** Open loop systems are generally defined as a system that is open to the atmosphere at any point. Depending on the governing code or code official's interpretation of the code an open loop system may include all or part of the potable water plumbing fixtures in a structure or may simply incorporate a drain valve or similar device that provides potable water and allows the system to be open to the atmosphere when operated. Consult local, State, Provincial, and Federal codes to determine requirements and applicability.

## Rinnai Tankless Water Heaters in Space Heating Applications

For further clarification Rinnai Tankless Water Heaters are certified for the following applications:

- Potable water
- Combination potable water/space heating applications where the Rinnai Tankless Water Heater is directly heating the potable water through its integral heat exchanger

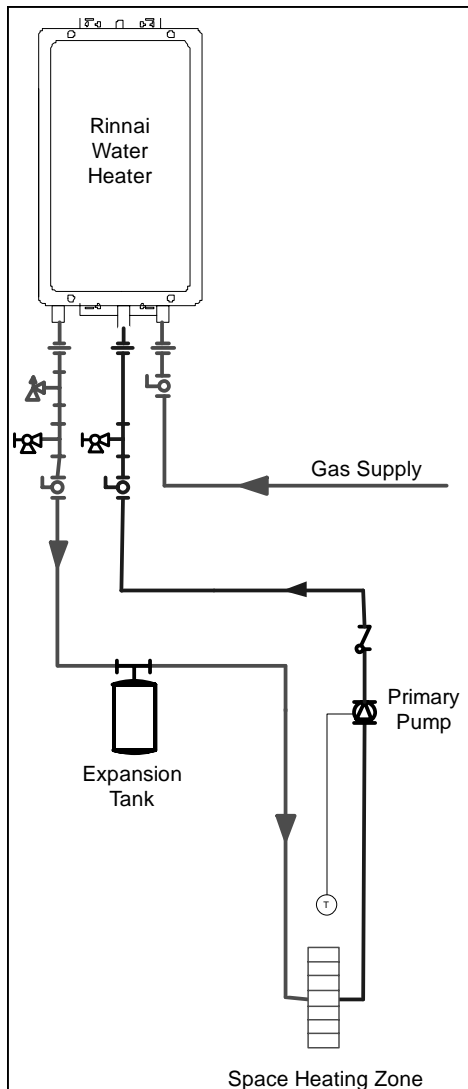

Figure 1: Space Heating Only  
(Closed Loop) System

**NOT RECOMMENDED**

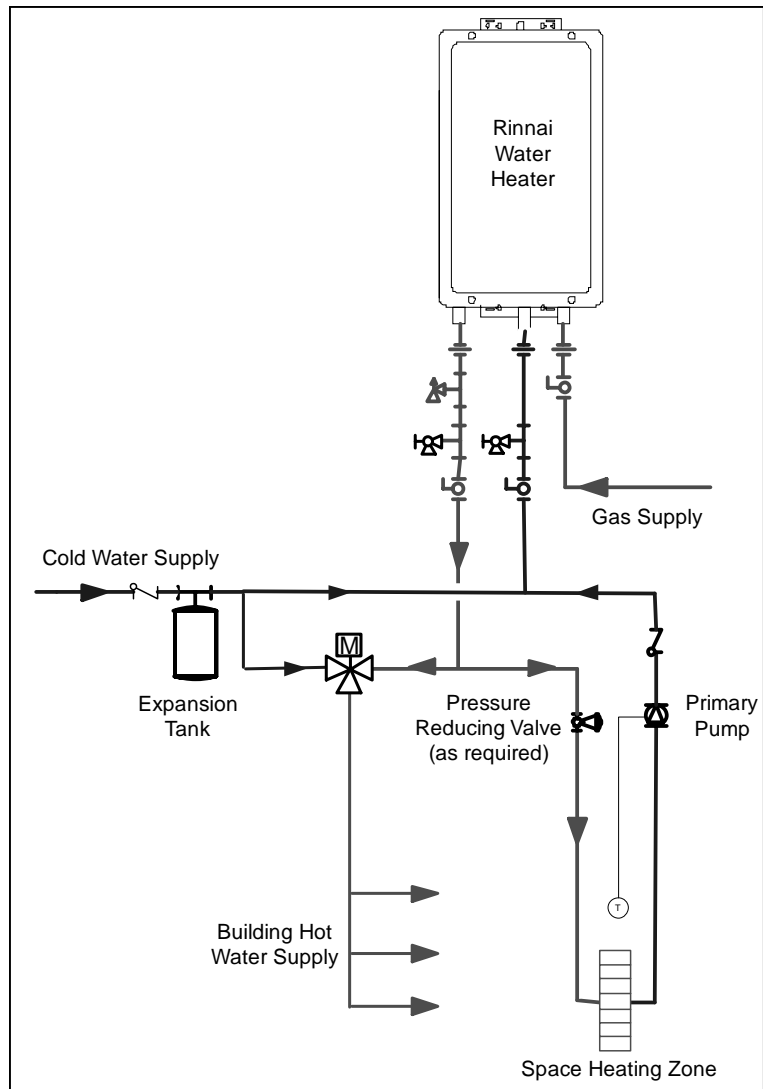

Figure 2: Combination Potable Water/Space Heating  
(Open Loop) System

**ACCEPTABLE**

# Rinnai Tankless Water Heaters in Space Heating Applications

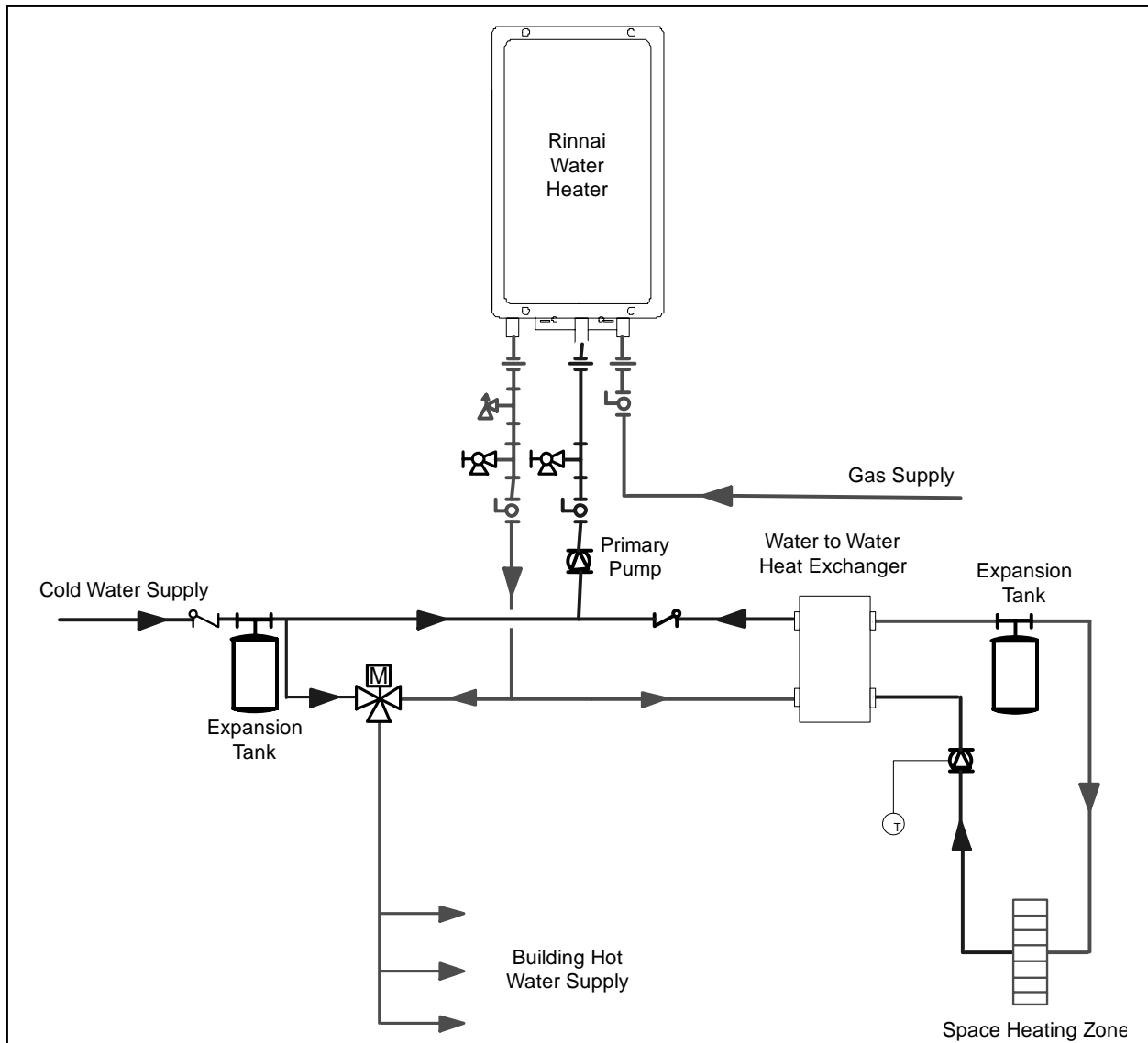

Figure 3: Combination Potable Water/Space Heating (Open Loop) System with Closed Heating Circuit

**ACCEPTABLE** ①

① Local, State, Provincial, and Federal codes must be adhered to prior to installation.